

vtech®

User's Manual

# SWITCH & GO® DINOS TURBO

*T-Rex Launcher*

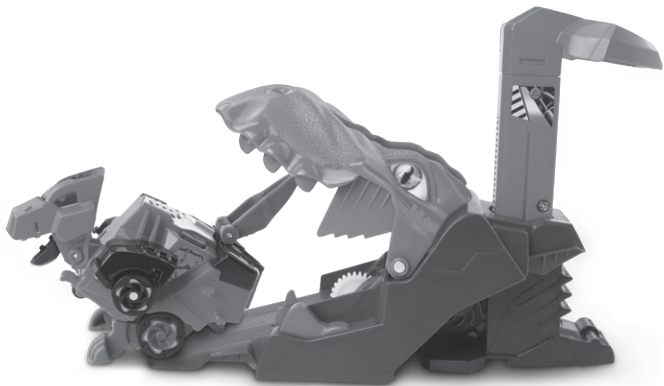

© 2014 VTech  
Printed in China  
91-009678-001 (UK)

**VTech understands that a child's needs and abilities change as they grow and with that in mind we develop our toys to teach and entertain at just the right level...**

## **vtech** *Baby*

**Toys that will stimulate their interest in different textures, sounds and colours**

### **I am...**

...responding to colours, sounds and textures

...understanding cause and effect

...learning to touch, reach, grasp, sit-up, crawl and toddle

*Birth-36 months*



## **Pre-School**

**Interactive toys to develop their imagination and encourage language development**

### **I want...**

...to get ready for school by starting to learn the alphabet and counting

...my learning to be as fun, easy and exciting as can be

...to show my creativity with drawing and music so my whole brain develops

*3-6 years*

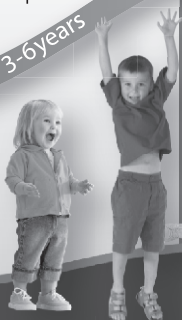

## **Electronic Learning Computers**

**Cool, aspirational and inspiring computers for curriculum related learning**

### **I need...**

...challenging activities that can keep pace with my growing mind

...intelligent technology that adapts to my level of learning

...National Curriculum based content to support what I'm learning at school

*4-10 years*



To learn more about this and other VTech® products, visit [www.vtechuk.com](http://www.vtechuk.com)

# INTRODUCTION

Get your **Switch & Go Dinos®** moving fast with the **T-Rex Launcher!** Open the launcher's to fit the dino in dinosaur or racecar mode, then power it up and GO! The faster you charge the T-Rex, the farther the launcher can blast it! Are you ready for some racing, roaring action? Let's go!

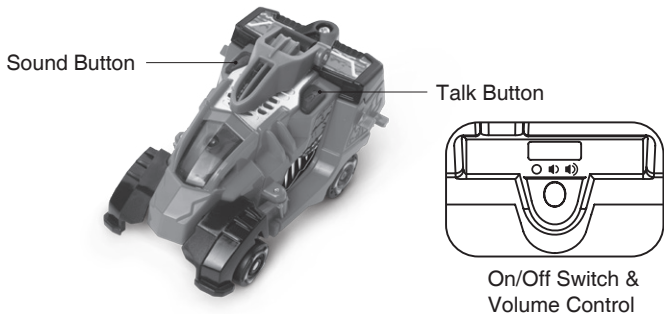
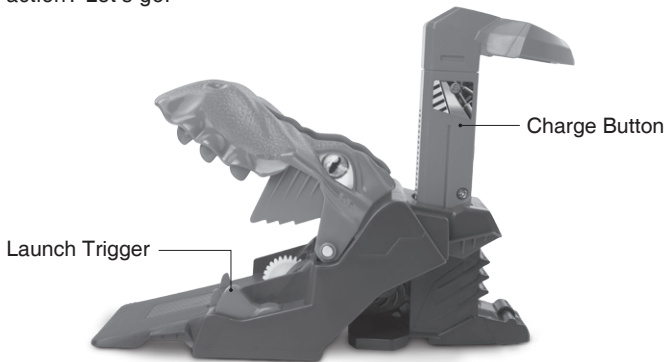

# INCLUDED IN THIS PACKAGE

- One VTech® Switch & Go Dinos® – T-Rex Launcher
- One VTech® Switch & Go Dinos® – Zipp the T-Rex
- One user's manual

## WARNING:

All packing materials, such as tape, plastic sheets, packaging locks and tags are not part of this toy, and should be discarded for your child's safety.

## NOTE:

Please keep the user's manual as it contains important information.

# GETTING STARTED

## BATTERY INSTALLATION

1. Make sure the unit is turned **OFF**.
2. Locate the battery cover on the bottom of the unit.
3. Install 1 new AAA (LR03/AM-4) battery following the diagram inside the battery box. (The use of new, alkaline batteries is recommended for maximum performance.)
4. Replace the battery cover to secure it.

**NOTE:** When the battery runs low, the toy will no longer respond. If this happens, please replace the battery.

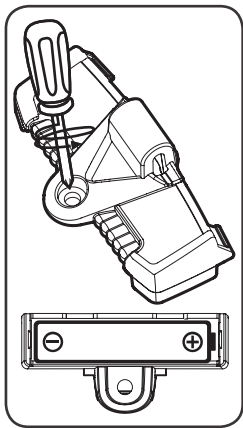

# BATTERY NOTICE

- Use new alkaline batteries for maximum performance.
- Use only batteries of the same or equivalent type as recommended.
- Do not mix different types of batteries: alkaline, standard (carbon-zinc) or rechargeable (Ni-Cd, Ni-MH), or new and used batteries.
- Do not use damaged batteries.
- Insert batteries with the correct polarity.
- Do not short-circuit the battery terminals.
- Remove exhausted batteries from the toy.
- Remove batteries during long periods of non-use.
- Do not dispose of batteries in fire.
- Do not charge non-rechargeable batteries.
- Remove rechargeable batteries from the toy before charging (if removable).
- Rechargeable batteries are only to be charged under adult supervision.

## Disposal of batteries and product



The crossed-out wheellie bin symbols on products and batteries, or on their respective packaging, indicates they must not be disposed of in domestic waste as they contain substances that can be damaging to the environment and human health.

The chemical symbols Hg, Cd or Pb, where marked, indicate that the battery contains more than the specified value of mercury (Hg), cadmium (Cd) or lead (Pb) set out in Battery Directive (2006/66/EC).



The solid bar indicates that the product was placed on the market after 13th August, 2005.

Help protect the environment by disposing of your product or batteries responsibly.

For more information, please visit:

[www.recycle-more.co.uk](http://www.recycle-more.co.uk)

[www.recyclenow.com](http://www.recyclenow.com)

# PRODUCT FEATURES

## LAUNCHER:

### 1. CHARGE BUTTON

Press the **Charge Button** to charge up the dino or car.

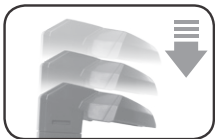

### 2. LAUNCHER TRIGGER

Press the **Launcher Trigger** to release the dino or car.

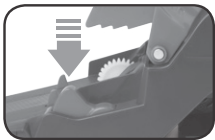

## ZIPP THE T-REX:

### 1. ON/OFF SWITCH & VOLUME CONTROL

This product has a single switch that turns the unit **ON** or **OFF** and controls the volume. To turn the unit **ON** or adjust the volume, slide the switch to Low/High. To turn the unit **OFF**, slide the switch to **OFF**.

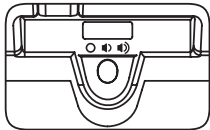

### 2. TALK BUTTON



Press the **Talk Button** to hear the dino or driver talk.

### 3. SOUND BUTTON



Press the **Sound Button** to hear cool sound effects.

#### 4. AUTOMATIC SLEEP MODE

To preserve battery life, the unit will automatically enter sleep mode if there's no input.

## HOW TO SWITCH THE DINO TO A VEHICLE

1. Dino shape.

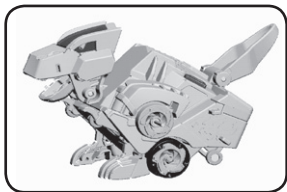

2. Move the head in and close its mouth.

(Note: When moving the head, the unit will automatically detect it has been switched into the vehicle shape and will respond accordingly.)

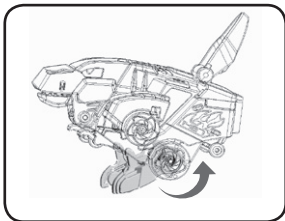
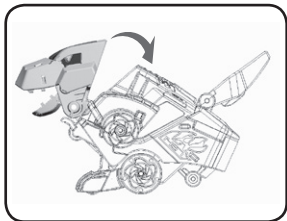

3. Rotate the back legs up.

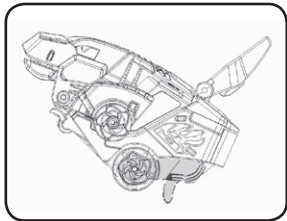

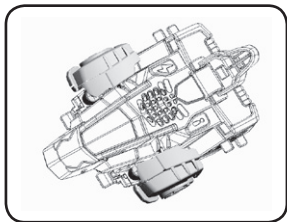

4. Pull out front wheels, then push them outside the body.

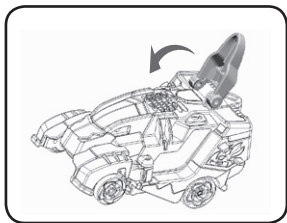
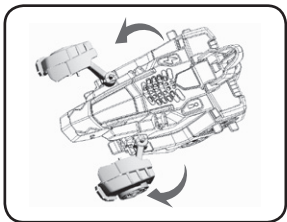

5. Fold the tail fin.

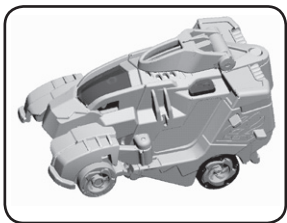

6. Car shape.

**Note:** To switch the vehicle back into a dino, reverse the order of the steps above.



# HOW TO CHARGE AND LAUNCH ZIPP THE T-REX

## 1. Put the Dino or Car into the Launcher.

To place the dino into the launcher, move the mouth of the dinosaur into the high position.



## 2. Press the Charge Button.

The more you charge the dino or car, the farther the launcher can blast it.



## 3. Press the Launch Trigger.

Press the launch trigger to release the dino or car.

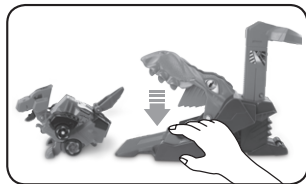

# CARE & MAINTENANCE

1. Keep the unit clean by wiping it with a slightly damp cloth.
2. Keep the unit out of direct sunlight and away from any direct heat source.
3. Remove the batteries when the unit is not in use for an extended period of time.
4. Do not drop the unit on hard surfaces and do not expose the unit to moisture or water.

# TROUBLESHOOTING

If for some reason the unit stops working or malfunctions, please follow these steps:

1. Please turn the unit **OFF**.
2. Interrupt the power supply by removing the battery.
3. Let the unit stand for a few minutes, then replace the battery.
4. Turn the unit **ON**. The unit should now be ready to play again.
5. If the product still does not work, replace with a new battery.

If the problem persists, please call our Consumer Services Department on 01235 546810 (from UK) or +44 1235 546810 (outside UK) and a service representative will be happy to help you.

## IMPORTANT NOTE:

Creating and developing **VTech®** products is accompanied by a responsibility that we take very seriously. We make every effort to ensure the accuracy of the information which forms the value of our products. However, errors sometimes can occur. It is important for you to know that we stand behind our products and encourage you to call our Consumer Services Department on 01235 546810 (from UK) or +44 1235 546810 (outside UK) with any problems and/or suggestions that you might have. A service representative will be happy to help you.



## PRODUCT WARRANTY



Thank you for choosing this quality product from VTech. We hope it will bring many hours of entertainment, imaginative play and learning.

1. The product detailed above is covered by a one year warranty from the date of purchase, against any defects in materials or workmanship.
2. The product may be returned to the place of purchase. Alternatively the product can be returned to VTech Electronics Europe plc (see address below), with proof of purchase, without proof of purchase no replacement will be provided.
3. VTech Electronics Europe plc will examine the product and if it is found to be defective due to faulty materials or workmanship, will replace the product at their discretion.
4. If the product covered by this warranty is damaged due to misuse, modification or unauthorised repair, or because of faulty batteries, battery discharge or incorrect electrical connections, then this warranty becomes void.
5. This warranty is personal to the original purchaser and is not transferable.
6. Breakages to the LCD screen are not covered by the warranty.
7. Returns to VTech Electronics Europe plc should include a cheque or postal order for £1.50 towards the cost of return postage and packaging.
8. Products returned to VTech Electronics Europe plc, should be addressed as follows and packed carefully to avoid damage in transit (Please do not include batteries or adaptor).  
Please include details of the fault together with your name and address.

VTech Electronics Europe plc, c/o Tablogix Limited, 200 Milton Park, Abingdon, Oxon OX14 4TA

**THIS WARRANTY IS OFFERED AS AN EXTRA BENEFIT AND DOES NOT AFFECT CONSUMERS' STATUTORY RIGHTS.**

This warranty is valid for the UK and Eire only. For products purchased outside the UK and Eire, please contact your local distributor or place of purchase.

